

The ELLIPSE Post Top Installation Instruction

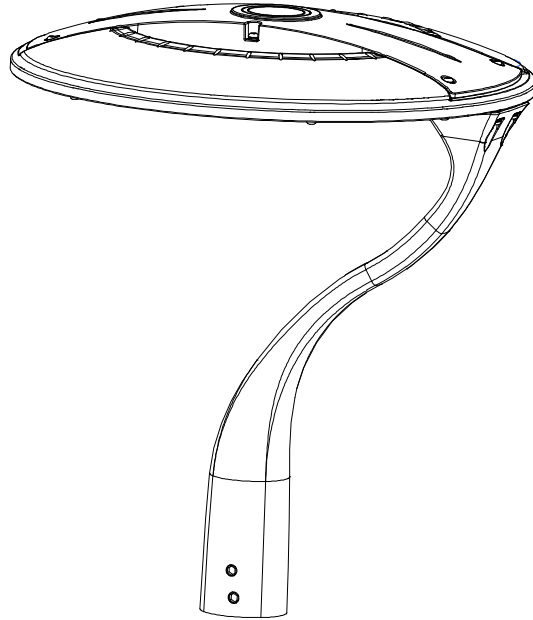

Please read the installation manual carefully before installation and keep the manual for future use.



Warning

1. Electrician must have related certificates, knowledge and working experience. The work must be assigned to each electrician based on their position and responsibility.
2. The lens of the lamp is PC + glass, which must be handled carefully during installation, otherwise will be easily scratched and damaged. When the face of the lamp is putting on the ground, it must be protected with soft cloth or other protective materials.
3. Installation must be proceeded when the electricity is shut off, no action taken if electricity connected.
4. Construction must be proceeded according to related regulations, including the tools and equipments used. For example: working voltage range, Warning sign, flashing lamp, helmet, and working clothes etc.
5. Make sure the weather is suitable for high power electricity work when proceed construction.



Statement

1. The crane used to install the courtyard lamp must come with lifting platform, warning signs and flash lamp etc.
2. Electric power must be cut off before installation or maintenance of Parking Lot Light.
3. Maintenance must be performed by professional staff.

Product parts include introduction

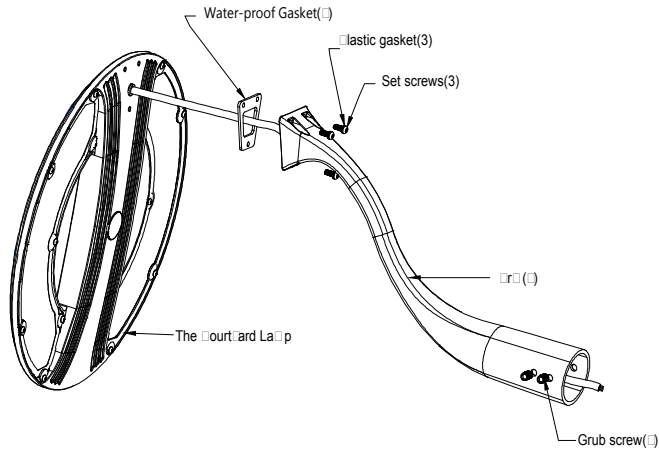

Preparation for installation of the courtiard lamp

Step 1: Place the waterproof gasket in the groove position of the lamp arm

Step 2: Put the wire through the arm

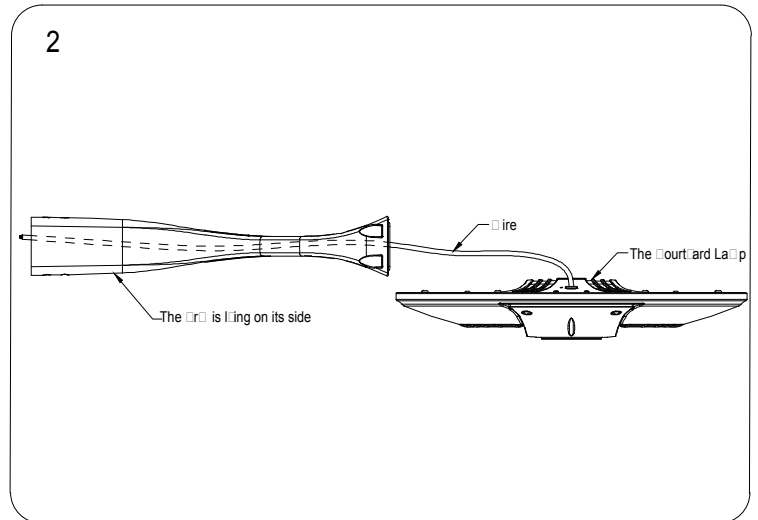
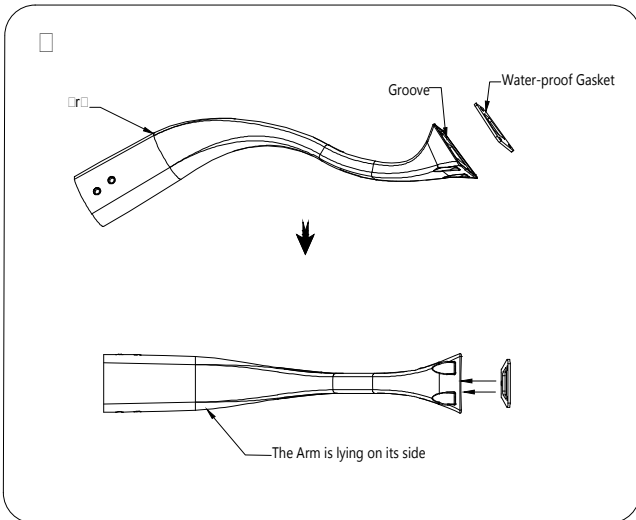

Step 3: Align the hole of bent arm with the lamp body's screw position

Step 4: Tighten the fixing screw with an inner hexagonal wrench. The torsion: 3-5 N·m

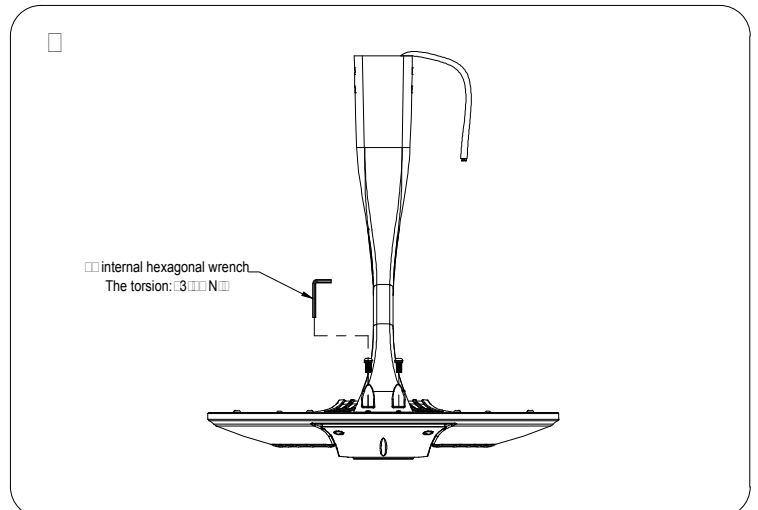
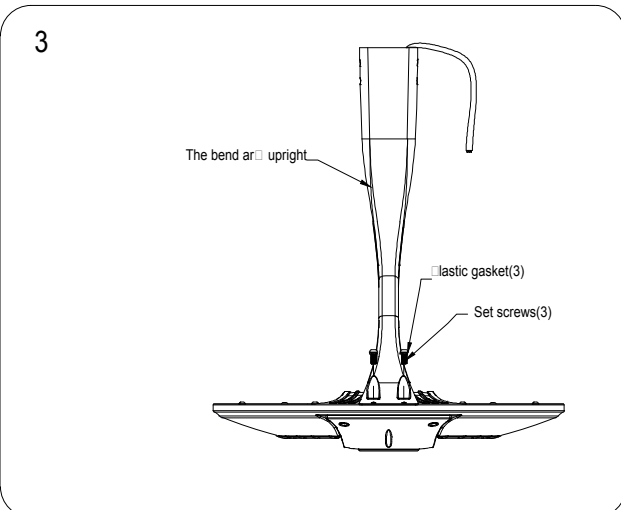

Step 1: Wiring, connect the L,N,GND wires on the lamp to the corresponding L,N,GND cables on the conduit

Step 2: Insert the elbow of the lamp into the lamp post and tighten fixing screws with an inner hexagonal wrench

The torsion: 19-22 N.m

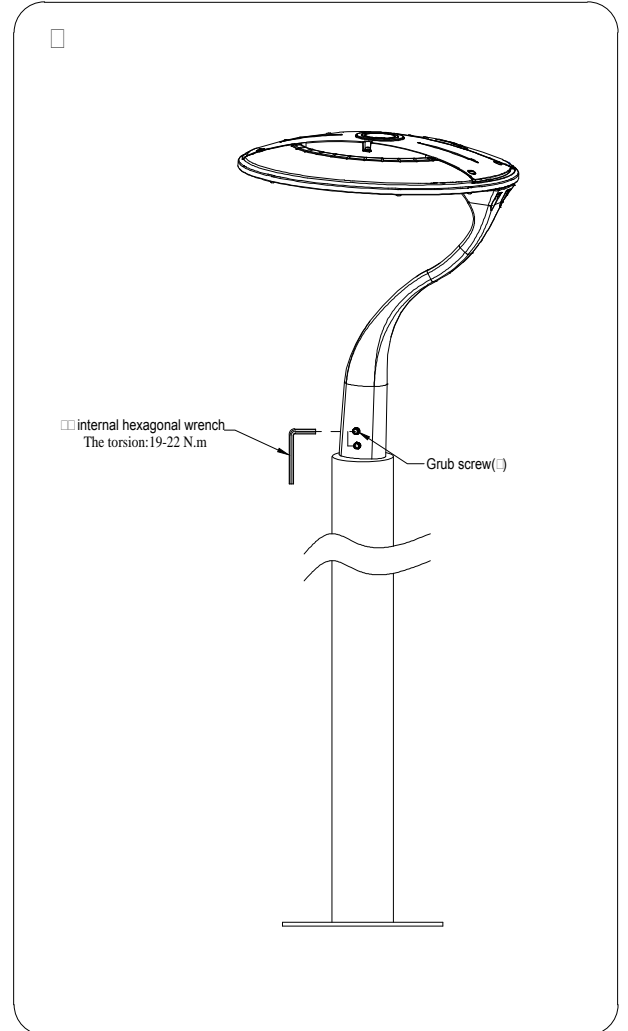
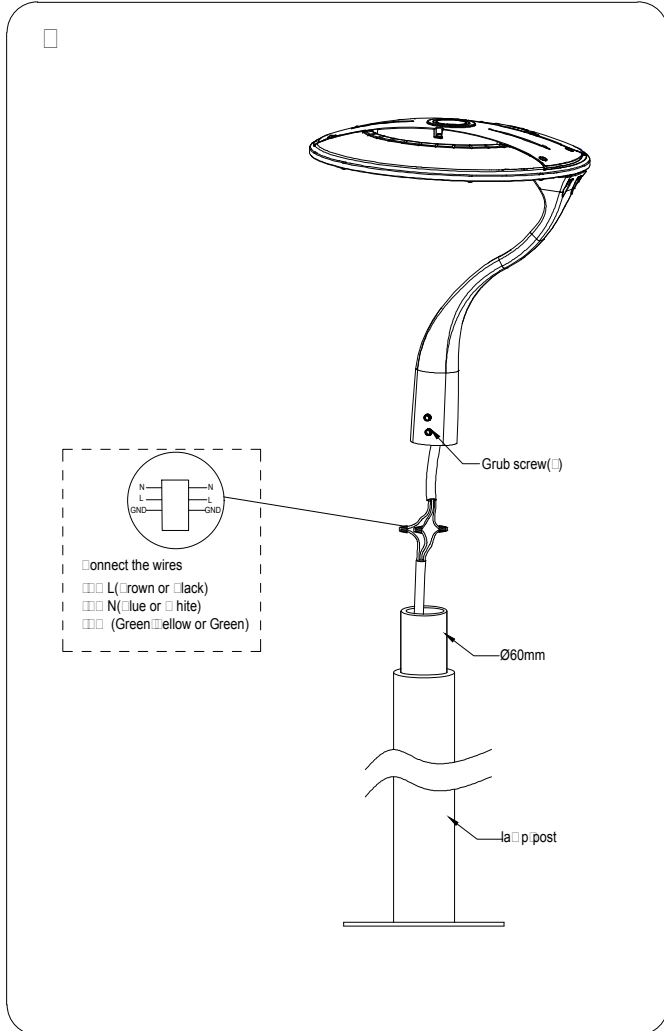

The ELLIPSE Post Top Installation Instruction

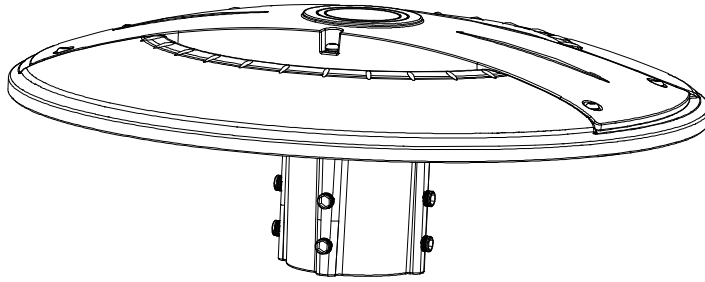

Please read the installation manual carefully before installation and keep the manual for future use.



Warning

1. Electrician must have related certificates, knowledge and working experience. The work must be assigned to each electrician based on their position and responsibility.
2. The lens of the lamp is PC + glass, which must be handled carefully during installation, otherwise will be easily scratched and damaged. When the face of the lamp is putting on the ground, it must be protected with soft cloth or other protective materials.
3. Installation must be proceeded when the electricity is shut off, no action taken if electricity connected.
4. Construction must be proceeded according to related regulations, including the tools and equipments used. For example: working voltage range, Warning sign, flashing lamp, helmet, and working clothes etc.
5. Make sure the weather is suitable for high power electricity work when proceed construction.



Statement

1. The crane used to install the courtyard lamp must come with lifting platform, warning signs and flash lamp etc.
2. Electric power must be cut off before installation or maintenance of Parking Lot Light.
3. Maintenance must be performed by professional staff.

Product parts include introduction

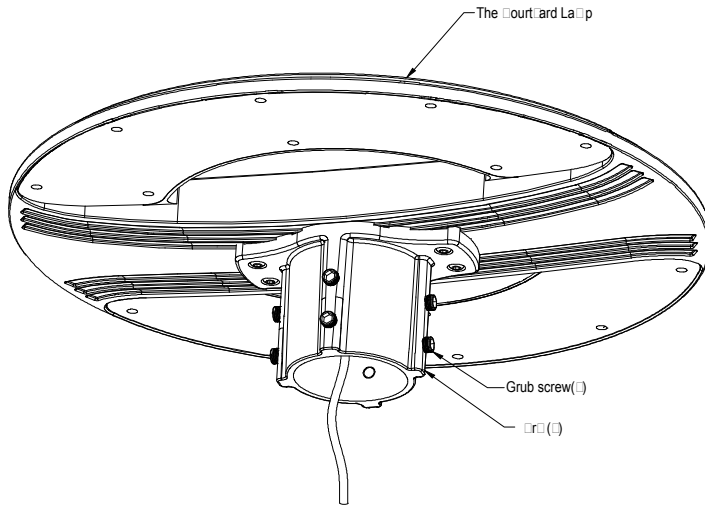

Preparation for installation of the outdoor lamp

Step 1: Wiring, connect the L,N,GND wires on the lamp to the corresponding L,N,GND cables on the conduit

Step 2: Insert the elbow of the lamp into the lamp post and tighten fixing screws with an inner hexagonal wrench

The torsion: 19-22 N.m

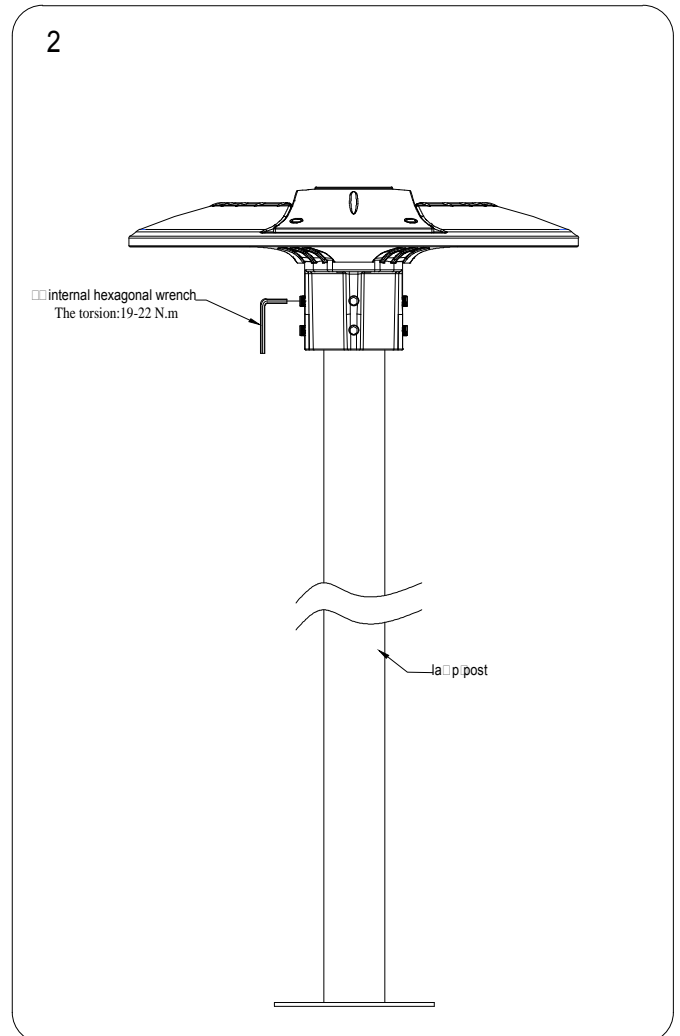
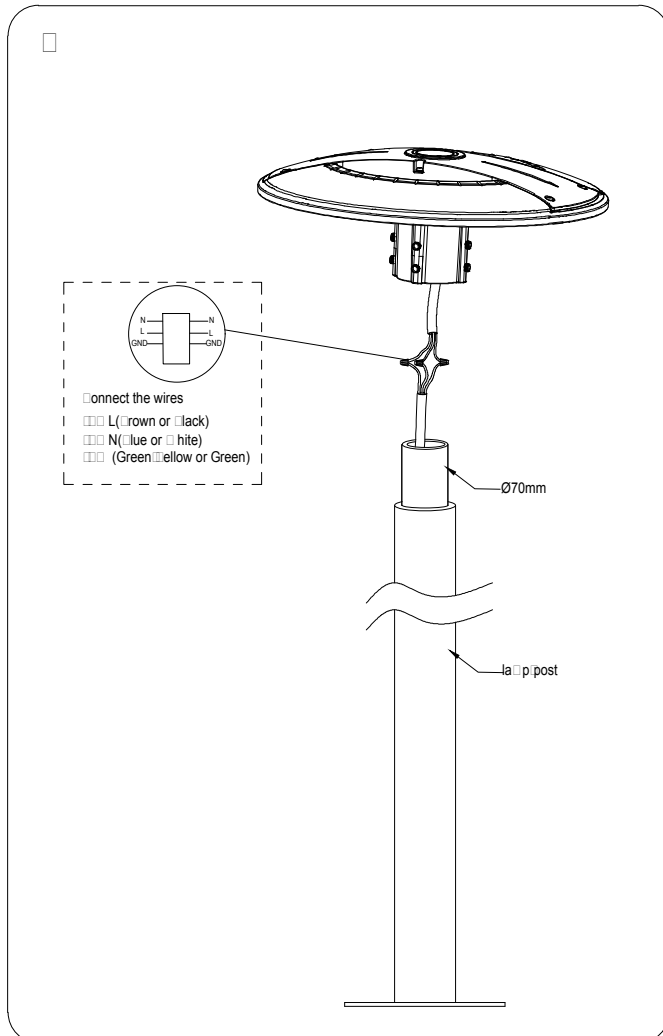

The ELLIPSE High Bay Installation Instruction

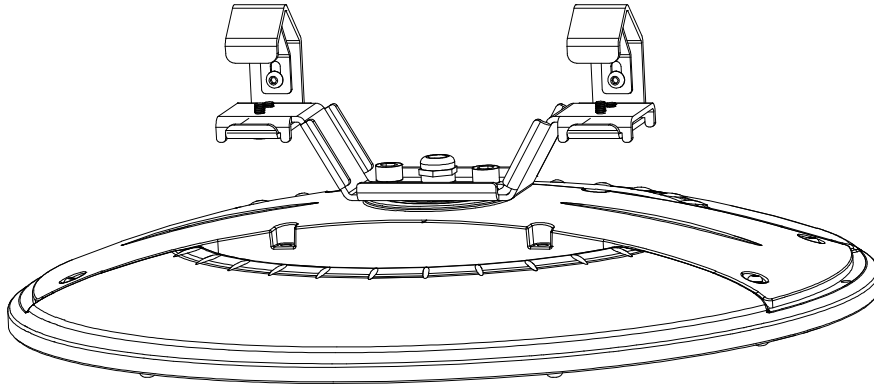

Please read the installation manual carefully before installation and keep the manual for future use.



Warning

1. Electrician must have related certificates , knowledge and working experience. The work must be assigned to each electrician based on their position and responsibility.
2. The lens of the lamp is PC + glass, which must be handled carefully during installation, otherwise will be easily scratched and damaged. When the face of the lamp is putting on the ground, it must be protected with soft cloth or other protective materials.
3. Installation must be proceeded when the electricity is shut off , no action taken if electricity connected.
4. Construction must be proceeded according to related regulations , including the tools and equipments used.
For example: working voltage range , Warning sign , flashing lamp , helmet , and working clothes etc.
5. Make sure the weather is suitable for high power electricity work when proceed construction.



Statement

1. The crane used to install the courtyard lamp must come with lifting platform, warning signs and flash lamp etc.
2. Electric power must be cut off before installation or maintenance of Parking Lot Light.
3. Maintenance must be performed by professional staff.

Product parts include introduction

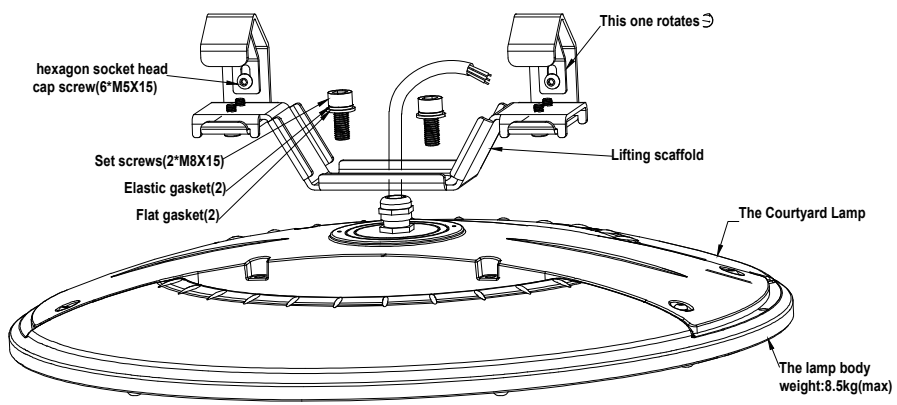

Preparation for installation of the Garden / Street Light

Step 1: Install the lifting bracket and fix the screw.

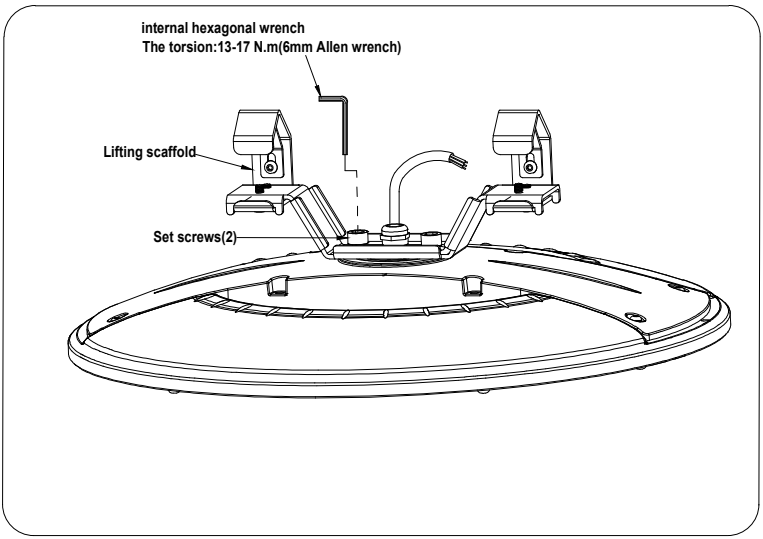
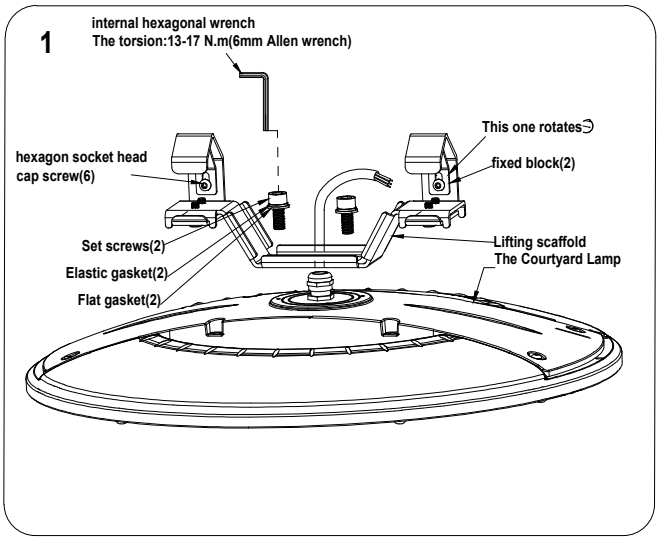

Step 2: The lifting bracket is fixed on the lamp body and then hung on the wire rope.

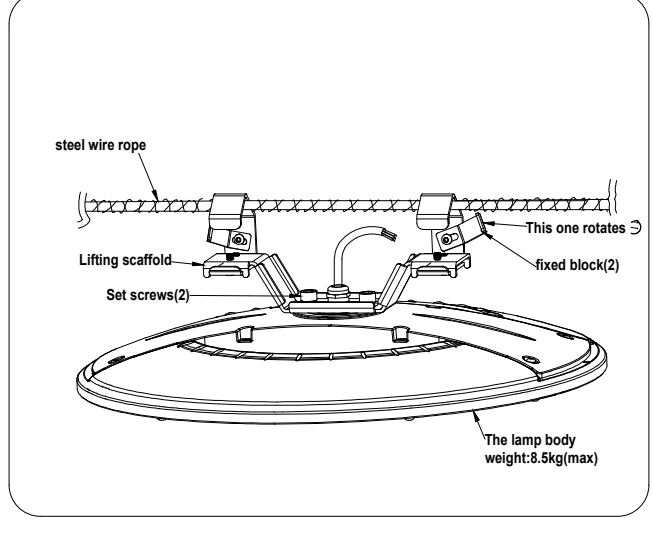
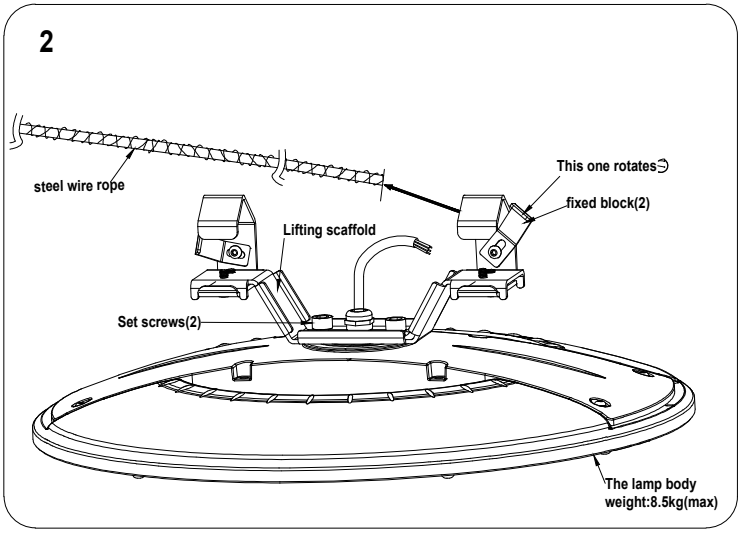

Step 3: pass the wire rope through the lifting bracket, adjust the position of the fixing block, and tighten the screws with the hex wrench to fix the position

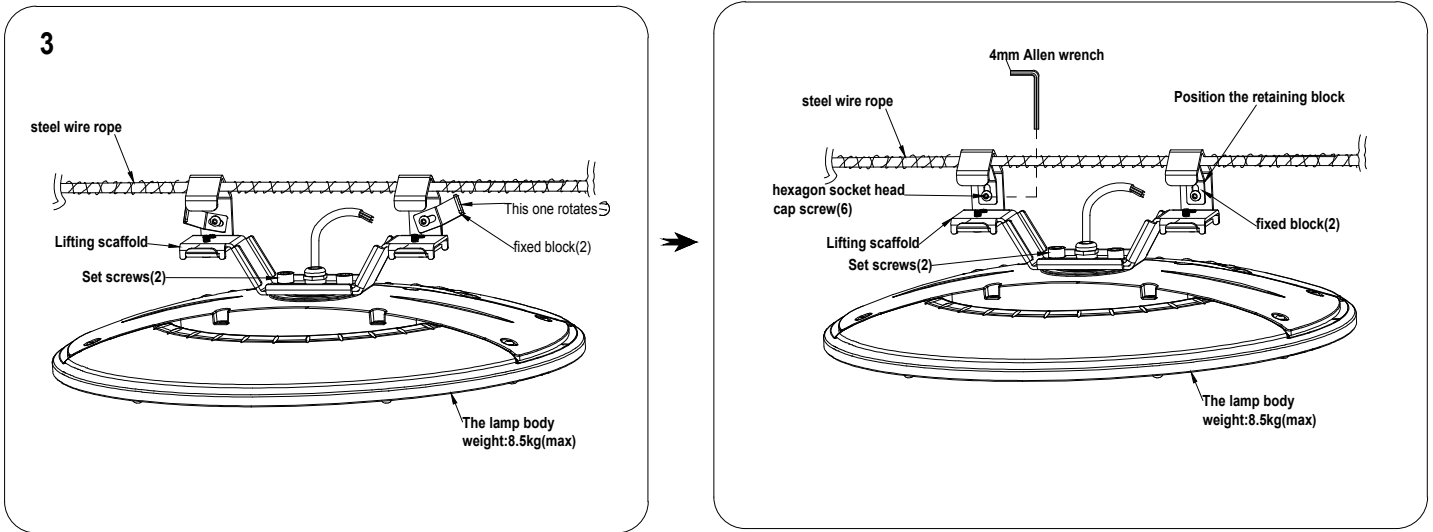

Step 4: Wiring, connect the L,N,GND wires on the lamp to the corresponding L,N,GND cables on the conduit.

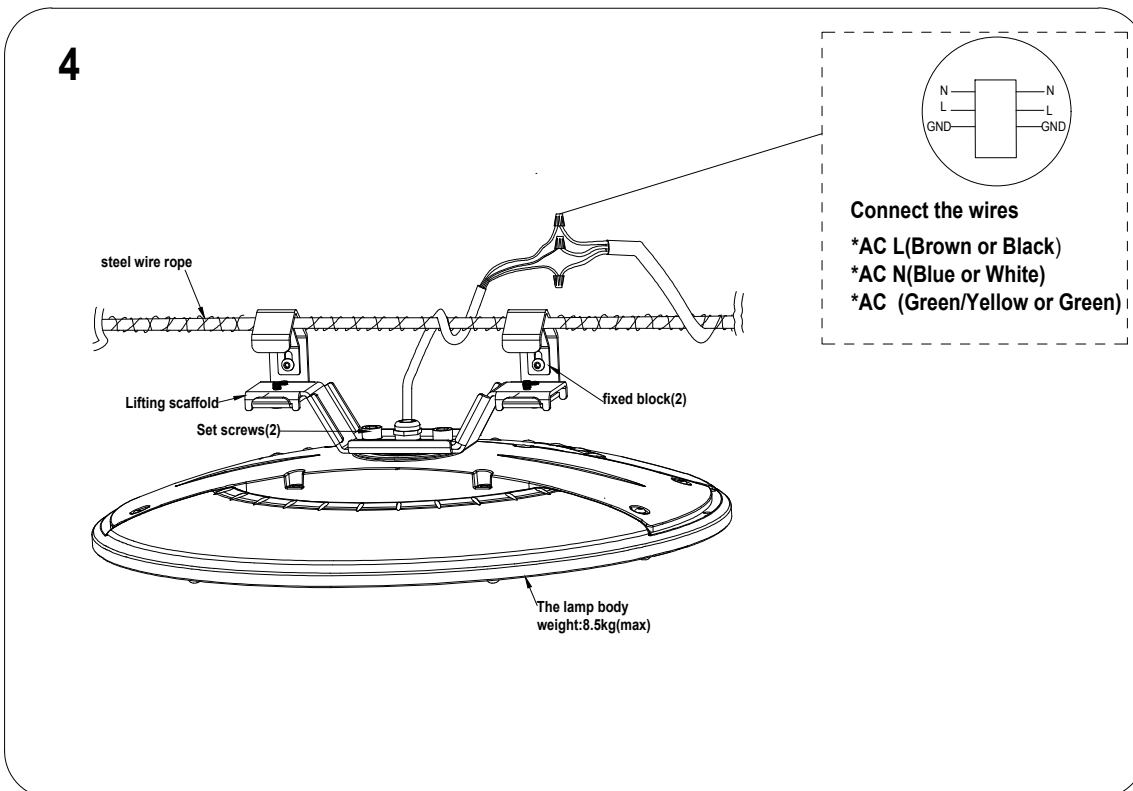

The ELLIPSE Area light Installation Instruction

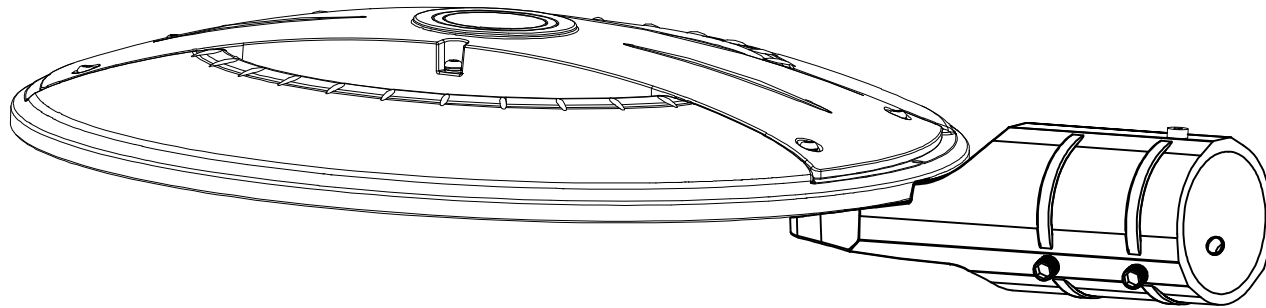

Please read the installation manual carefully before installation and keep the manual for future use.



Warning

1. Electrician must have related certificates , knowledge and working experience. The work must be assigned to each electrician based on their position and responsibility.
2. The lens of the lamp is PC + glass, which must be handled carefully during installation, otherwise will be easily scratched and damaged. When the face of the lamp is putting on the ground, it must be protected with soft cloth or other protective materials.
3. Installation must be proceeded when the electricity is shut off , no action taken if electricity connected.
4. Construction must be proceeded according to related regulations , including the tools and equipments used. For example: working voltage range , Warning sign , flashing lamp , helmet , and working clothes etc.
5. Make sure the weather is suitable for high power electricity work when proceed construction.



Statement

1. The crane used to install the courtyard lamp must come with lifting platform, warning signs and flash lamp etc.
2. Electric power must be cut off before installation or maintenance of Parking Lot Light.
3. Maintenance must be performed by professional staff.

Product parts include introduction

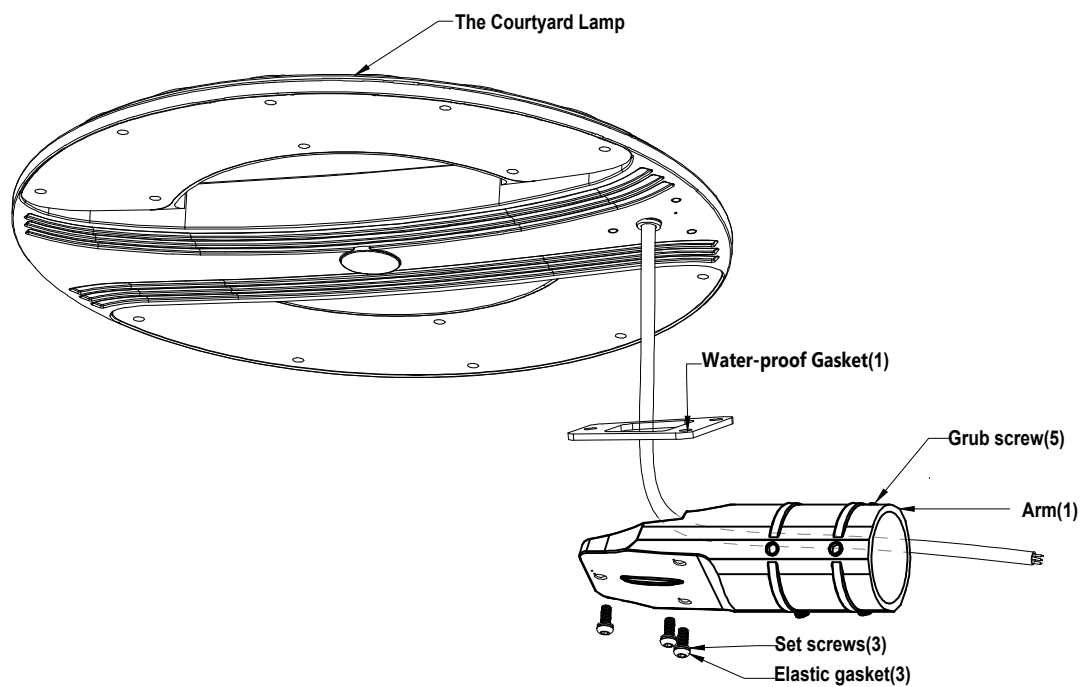

Preparation for installation of the courtyard lamp

Step 1: Place the waterproof gasket in the groove position of the lamp arm.

Step 2: Put the wire through the arm.

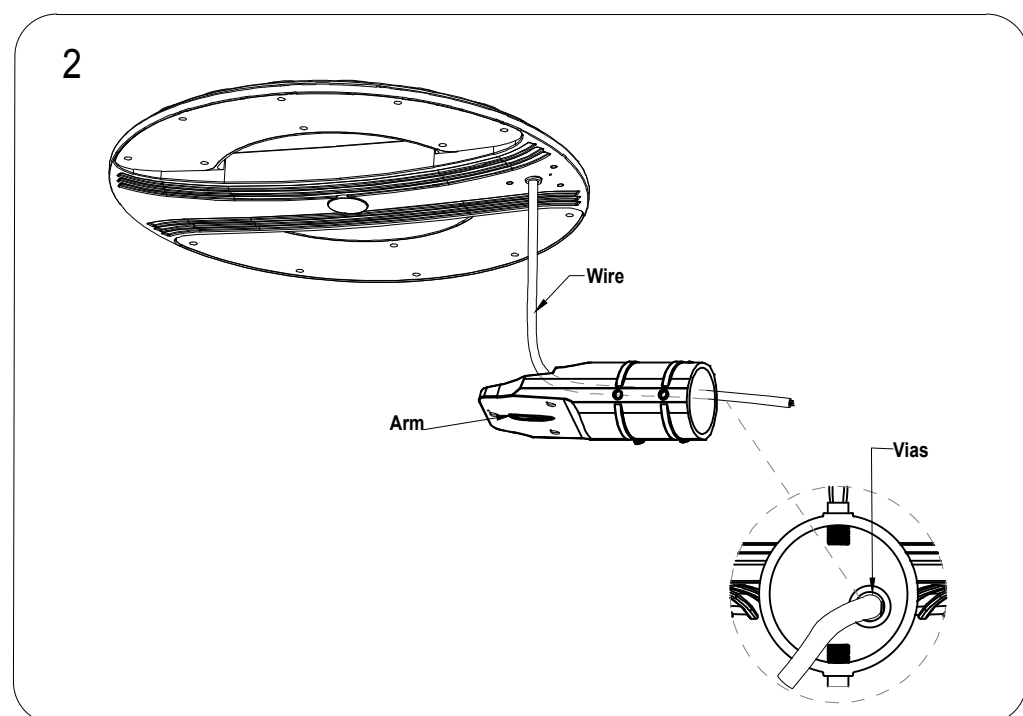
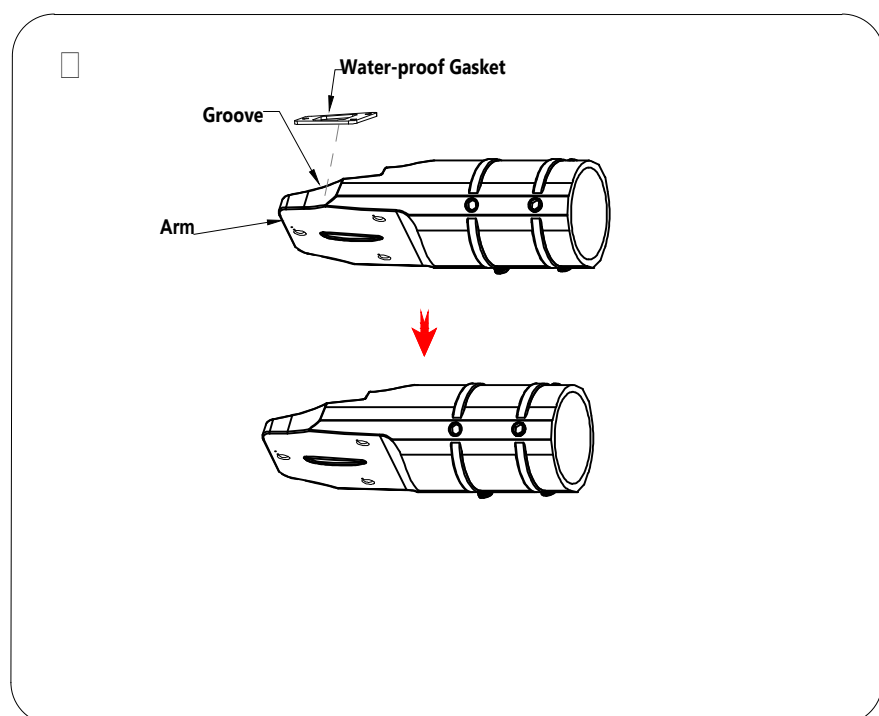

Step 3: Align the hole of bent arm with the lamp body's screw position.

Step 4: Tighten the fixing screw with an inner hexagonal wrench. The torsion: 13-17 N*m.

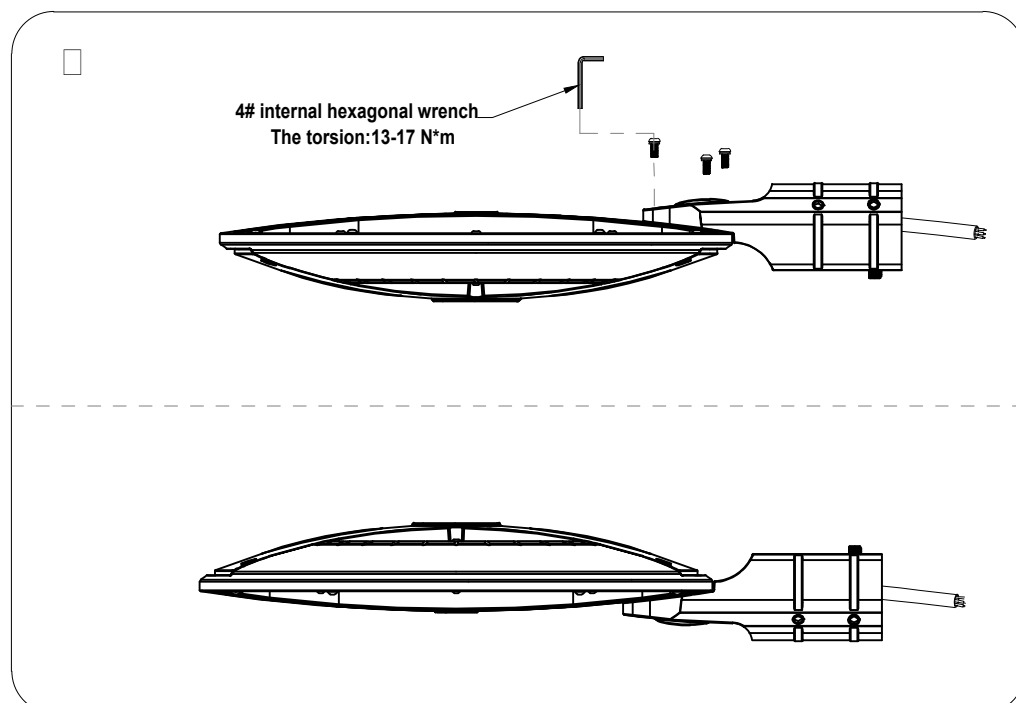
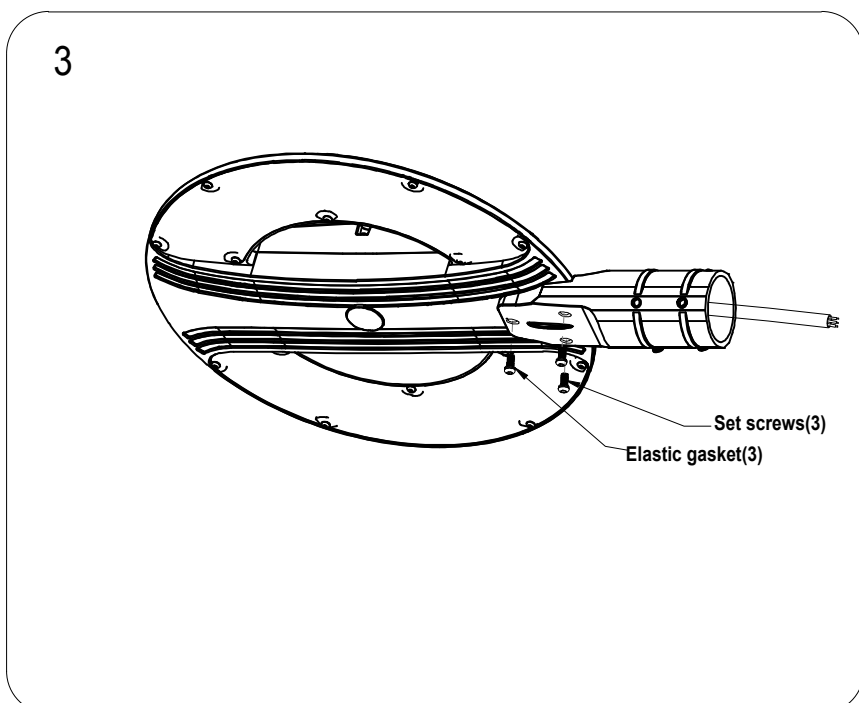

Step 5 : Wiring, connect the L,N,GND wires on the lamp to the corresponding L,N,GND cables on the conduit.

Step 6 : Insert the elbow of the lamp into the lamp post and tighten 4 fixing screws with an inner hexagon wrench.

The torsion:19-22 N.m

