

AG ALL GREEN LIGHTING, INC.

ASTRO-3 Series

Product Description:

The ASTRO-3 Series improves upon the original ASTRO model, providing a slim, sleek housing body; a new unique pin heatsink design, superior lumen output, a wide range of wattages and a variety of lighting distributions, UV stabilizing materials, and 20kV surge protection comes standard. Various accessories available as well to help fulfill any of your lighting needs.

Features:

- **Application:** LED High Mast, Sportlight
- **Mounting:** U-Bracket, Slipfitter for lower wattages
- **Warranty:** 5 years
- **LED Source:** Seoul Semiconductor
- **Operating Temperature:** -40°F ~+ 122°F

Technical Data:

Certifications	ETL
CRI	≥ 70 (CRI 80 & 90 available)
IP Rating	IP66
CCT	4000K ~ 5700K
Input Voltage	100-277V, 100-240V, 347-480V



240W-1200W



1440W

Specifications:

Fixture Model	Total Lumens (5000K/CRI70)	Efficacy (lm/w)	Dimensions in Inches (L x H x W)	Weight (lbs)	EPA (ft ²)	Beam Angle
ASTRO-3-240W	36,720 lm	153 lm/W	15.1"L x 14.9"H x 7.36"W	29.48	0.858	21°x21° 30°x30° 40°x40° 60°x60° 90°x90°
ASTRO-3-320W	48,960 lm	153 lm/W		29.81		
ASTRO-3-400W	60,800 lm	152 lm/W		32.89		
ASTRO-3-500W	75,500 lm	151 lm/W		32.45		
ASTRO-3-600W	91,200 lm	152 lm/W	18.9"L x 18.98"W x 7.48"W	50.27	1.15	
ASTRO-3-750W	113,250 lm	151 lm/W		50.93		
ASTRO-3-960W	136,320 lm	138 lm/w	21.65" x 21.77" x 4.13"	71.06	1.65	21°x21° 30°x30° 40°x40° 60°x60°
ASTRO-3-965W	141,855 lm	147 lm/W		72.6		
ASTRO-3-1200W	177,600 lm	144 lm/W		77.44		
ASTRO-3-1440W	204,480 lm	138 lm/w		78.76		

Dimensions:

240W / 320W / 400W / 500W

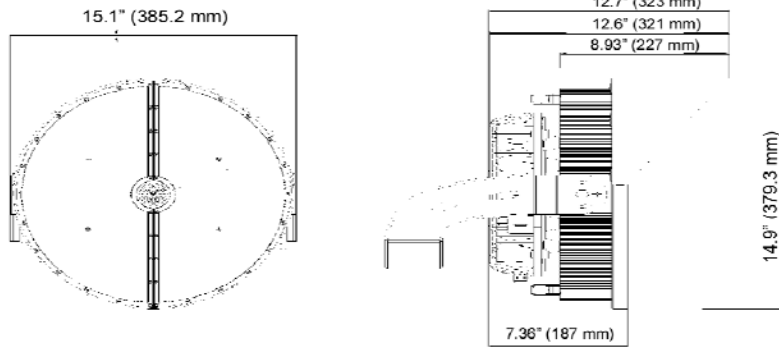

600W / 750W

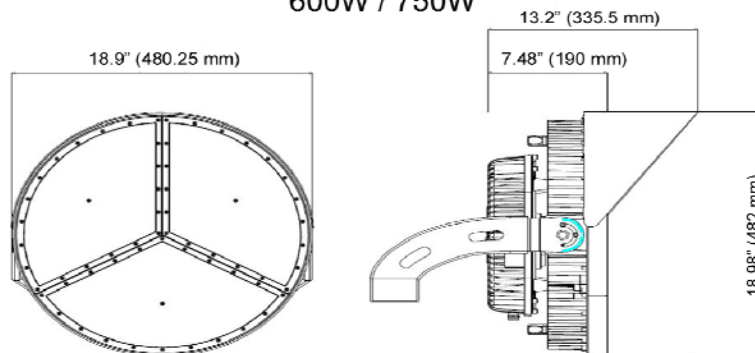

960W / 965W / 1200W / 1440W

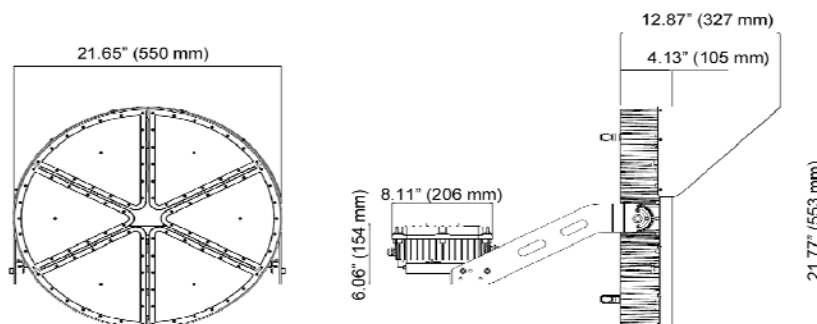

Ordering Guide:

ASTRO-3-600W	100-277V	BR	40K	40° x 40°	U	
Wattage:	Voltage:	Color:	CCT:	Beam Angle:	Mount:	Optional Accessories*
240W	100-277V	BR: Bronze	40K	<u>240W-790W</u>	U: U-Bracket (all wattages)	DM: 0-10V Dimmable
320W	100-240V	BL: Black**	50K	21° x 21°		VS: Visor
400W	347-480V*	WH: White**	57K	30° x 30°		MS: Motion Sensor
500W				40° x 40°	SF: Slipfitter (240W-500W only)	CR180
600W				60° x 60°		CR190
750W				90° x 90°		3PR: 3-Pin Receptacle (240W-1200W only)
960W				(240W-500W only)		3PC: 3-Pin Photocell (240W-1200W only)
965W						SC: Shorting Cap
1200W						
1440W						

*Additional costs may apply

** MOQ 50 units for black or white